



PRIVATE GLOBAL
TRADING AGENCIES



SAFETY FIRST | **BE** | **SAFETY FIRST**
CAREFUL

**SAFETY
BEGINS HERE**

Excellent Service



PRIVATE GLOBAL
TRADING AGENCIES

PG PRIVATE GLOBAL
TRADING AGENCIES

PG PRIVATE GLOBAL
TRADING AGENCIES

SIMPLE SOLUTIONS, SIGNIFICANT BENEFITS.



WORLDBLINK MASTERS General Trading L.L.C. is a professional distributor of road traffic safety equipments, LED display products and road safety products.

We established this company due to increasing demands of our products and services and to make it more convenient to our local clients to reach us.































We are a leading enterprise in Gulf Cooperation Council (GCC) production of solar electric products, and we are also one of the major distributors in the current domestic production of transportation products.

We implement modern management system; adhere to the scientific and technological innovations and practices power - power association with research institutes and colleges. We put personalization into our products and constantly developing new products with high-end smart, high luminous efficiency and ultra low-power consumption solar warning lamp series, solar traffic safety sign series, solar traffic light series, solar screen series, solar warning screen series and road safety products.

Our products are well received and recognized domestically and are widely used in the public security, transportation, navigation, power, telecommunication and other related fields.

We earn and build a good relationship to our client as we always focus on the safety, quality, efficiency and durability of products.



Black Base PVC Cone 4 	Orange Base PVC Cone 5 	Rubber Traffic Cone 6 	PE Traffic Cone 6 	PVC Traffic Cone 7 	Cone Toppers 8 	Traffic Cone Bar 9 
Cone Accessories 9 	Portable Speed Hump 10 	Speed Humps 11-13 	Rubber Ped Xing 14 	Lane Separators 15-17 	Delineator 18 	T-Top Delineator Post 19 
Lane Divider 19 	Flexible Delineator 20-21 	Barriers 22-25 	Barriers 22-26 	Parking Locks 27 		
Road Studs 28 	Non-Reflective Pavement Marker 29 	Barricade Lights 30 	Traffic Baton 30 	Chains & Tapes 31 	Mirrors 32 	Road Signs VMS 33 
VMS 34 	VMS 35 	Mobile Traffic Lights 36-37 	Multifunctions Arrow Boards 38 	Arrow Boards 39 		

Black Base PVC Traffic Cone

America & Australia Model

“ WMG PVC Traffic Cones are made up of Fluorescence Orange PVC Cone Body and recycled materials black base. The two parts interlock as a single inseparable piece, and would not separate even truck run over it.”

- *Ten Times Life Than PE & Rubber Traffic Cone*
- *Fluorescence Orange with 2 years warranty*
- *Meet American MUTCD Standard*



Item No.	Height	Base Width	Cone Diameter	Weight	Reflex
PG-DH-TC-90	910mm (36")	360mm	230mm	4.5kg (10lbs)	100mm 150mm
PG-DH-TC-90B	910mm (36")	360mm	230mm	5.5kg (12lbs)	100mm 150mm
PG-DH-TC-90W	910mm (36")	360mm	260mm (Wide Body)	4.5kg (10lbs)	100mm 150mm
PG-DH-TC-90WB	910mm (36")	360mm	260mm (Wide Body)	5.5kg (12lbs)	100mm 150mm
PG-DH-TC-90S	910mm (36")	360mm	260mm (Slim Body)	4.5kg (10lbs)	100mm 150mm

Orange Base PVC Traffic Cone

General Model

- Single Piece Made from Fluorescence Orange PVC
- Environmentally friendly - 100% recyclable!
- Extreme durability & superior flexibility!



Item No.	Height	Base Width	Cone Diameter	Weight	Reflex
PG-DH-TC-30R	300mm (12")	220mm	140mm	0.7kg (1.5lbs)	NO
PG-DH-TC-45R	450mm (18")	270mm	190mm	1.1kg (2.5lbs)	150mm
PG-DH-TC-45RB	450mm (18")	270mm	190mm	1.4kg (3lbs)	150mm 100mm
PG-DH-TC-70R	710mm (28")	360mm	260mm	2.3kg (5lbs)	150mm 100mm
PG-DH-TC-70RS	710mm (28")	360mm	280mm	2.6kg (6lbs)	150mm 100mm
PG-DH-TC-70RB	710mm (28")	360mm	260mm	3.1kg (7lbs)	150mm 100mm
PG-DH-TC-90WR[42]	910mm (36")	360mm	260mm	4.2kg (9lbs)	150mm 100mm
PG-DH-TC-90WR[45]	910mm (36")	360mm	260mm	4.5kg (10lbs)	150mm 100mm

Rubber Traffic Cone

Made From
Recycled Tire Rubber
and Painted Red and White.



Model No.	PG-DH-LZ-1	PG-DH-LZ-2	PG-DH-LZ-3	PG-DH-LZ-4	PG-DH-LZ-5	PG-DH-LZ-6
Base	280mm	350mm	280mm	350mm	280mm	350mm
Height	500mm	700mm	500mm	700mm	500mm	700mm
Weight	1.5kg	2.2kg	2.0kg	2.8kg	2.0kg	2.8kg



PE Traffic Cone

Blowing
PE Cone Body locked
with recycled rubber base.

Model No.	PG-DH-PE-1	PG-DH-PE-2	PG-DH-PE-3	PG-DH-PE-4	PG-DH-PE-5	PG-DH-PE-6
Base	280mm	350mm	490mm	400mm	350mm	260mm
Height	500mm	700mm	1000mm	750mm	750mm	500mm
Weight	1.5kg	2.5kg	5.0kg	4.0kg	2.0kg	0.6kg

PVC Traffic Cone

European Model

- *Recessed Handle for easy carry and moving*
- *Meet most European Countries Standards.*



Item No.	Height	Base Width	Cone Diameter	Weight	Reflex
PG-DH-TC-75R	750mm	220mm	280mm	4.2kg	
PG-DH-TC-50R	500mm	270mm	200mm	1.0kg	
PG-DH-TC-75	750mm	400mm	280mm	4.2kg	150mm 150mm
PG-DH-TC-50	500mm	280mm	200mm	2.5kg	100mm 100mm

CONES TOPPERS



3m - 12m
for options.
Red/White,
Yellow/Black

Retractable Traffic Cone Topper

The Retractable traffic cone Topper is the ideal way to cordon off any area, instantly transforming a space into a safe work area. It simply clicks on top of most traffic cones, saving time, storage space and money. The Retractable traffic cone is unique in that it manages to provide 3Meter -12Meter of untearable safety tape, which is unrivaled in the barrier industry. The units come with a clever braking mechanism which allows easy use in high winds and inclement weather conditions.

Retractable traffic cone Topper can be used in a wide variety of situations :

Airport Safety Solutions | Mining and Outdoor Use | Construction Safety Management | Event Management | Safety Management Solutions



Model No.	Tape Length	Topper Height	Topper Width	Bottom Hole	Weight
PG-DH-TOP-1	3 meter	240mm	140mm	900mm	400g
PG-DH-TOP-2	6 meter	240mm	140mm	900mm	600g
PG-DH-TOP-3	8 meter	240mm	140mm	900mm	800g
PG-DH-TOP-4	12 meter	240mm	140mm	900mm	100g

Retractable Traffic Cone Topper

Red and White diagonal stripes belt and is conveniently designed to fit over most standard traffic cones. With its 4 way connectivity, it is easy to use and proves to be a quick and effective way to restrict access.



Product Dimension
Tape Length: 5.0meter
Tape Width: 50mm
Height.: 200mm
Width: 100mm
Available Colors:
White/Red; Yellow/Black



Retractable Traffic Cone Bar

Product Dimension

Original Length: 1300mm
Expanded Length: 2300mm
Pole Dia.: 40mm
O-ring Dia.: 105mm
Available Colors:
White/Red; Yellow/Black

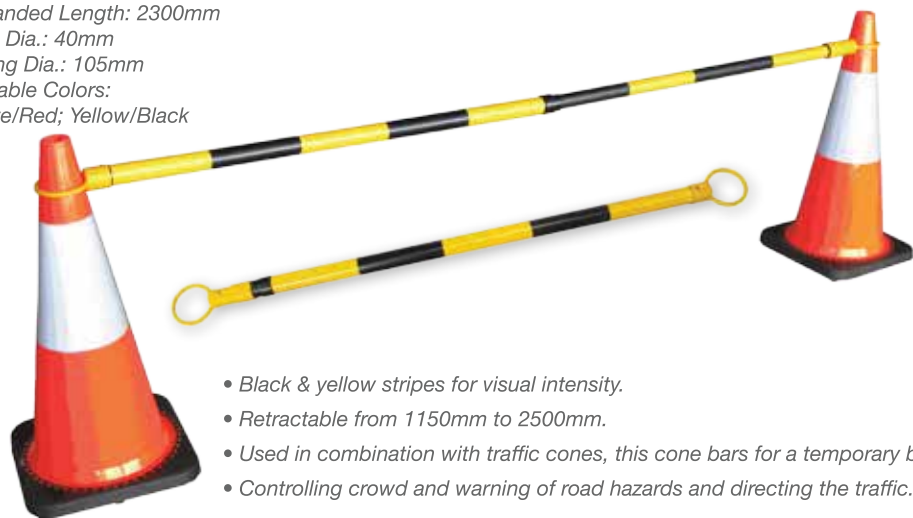

- Black & yellow stripes for visual intensity.
- Retractable from 1150mm to 2500mm.
- Used in combination with traffic cones, this cone bars for a temporary barrier.
- Controlling crowd and warning of road hazards and directing the traffic.

Flash Traffic Cone Bar

PG-SL-3 Model



- Topper conveniently.
- 105mm O-ring for fixing onto traffic cones.
- 3pcs AA Batteries inside.
- 2m length and 10mm diameter bar.
- 10pcs super bright LED inside for providing obvious flashing lighting at night.



Traffic Cone Collar

- Reflexite®
- Engineer Grade Reflective Sleeve
- High Intensity Self Adhesive Reflective sheet



Traffic Cone Sign

Model: PG-DH-TC-S1

Dimension: 32mmx266mmx5mm

- Specially cut grooves attach securely to traffic cones and are easily removed.
- Customize any words traffic cone sign to meet your needs.



Flash Traffic Cone Lamp

PG-SL-2 Model

- 4pcs flash led inside, automatically turn on at night.
- 500m visual.
- 2pcs D- Batteries inside
- 500hrs continuous working time.
- Cone-Shape Cover for fitting onto various cones.



Traffic Cone Lamp

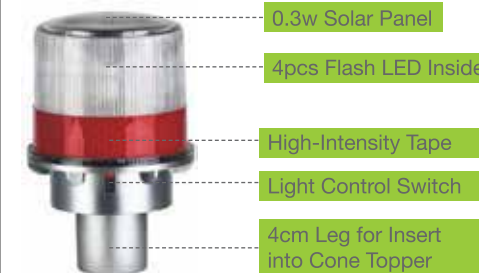

PG-SL-1

LED Top Light

PG-DH-RC-T

- Dimension: 5x5x4cm
- Weight: .01kg
- Use to be added on the road cone.
- Low-watt density of longer service life



LED Bottom Light

PG-DH-RC-B

- Dimension: 5x5x4cm
- Weight: .01kg
- Use to be added on bottom of cone.
- Low-watt density of longer service life



Portable Speed Hump

PP Materials

The highly visible system is designed for temporary speed control applications, where it is desired to slow traffic speeds to 40km/hr. The secret behind the success of the system is its unique "waffle style" rubber underlay, which maximises the adhesion to the road surface as vehicle traverse.

It has been designed for use around highway work zones to assist in reducing speed.



Model No.	Max Length	Width	Height	Weight	Roll Up Size	Bearing Weight
PG-DH-PSP-2	3000mm	250mm	45mm	13kg	540mm Dia.	10Tons

Portable Speed Hump

Portable speed bumps are made from durable PU materials that have all the benefits of stationary speed bumps, but can be folded up and moved from location to location in seconds. Perfect for calming traffic during certain hours of the day, such as immediately before and after school. Portable, foldable speed bumps weigh less than 12kg and are easily handled by one person.

- Easily Installation, No screws/adhesive required.
- Highly visible and reflective at night.
- Usable in all weather conditions.
- Can withstand any size vehicle.
- Easy to remove and roll up back into carry case.
- Polyurethane raw materials.



Model No.	Max Length	Width	Height	Weight	Folded Size	Bearing Weight
PG-DH-PSP- 1	3000mm	250mm	25mm	11kg	360x250x310mm	20Tons

Round Solar Speed Hump

The highly visible system is designed for temporary or permanent use. Made from Yellow Polyurethane, with 6 flashing LED at night. Perfect for all road use.

Product Dimension
Model No.: PG-DH-RSP-1
 Diameter: 300mm
 Height: 45mm
 Weight: 1.0kg
 Reflector: 6 Solo Flash LED
 Bearing Weight: 20Tons



* Pre-molded nut for fixing the solar stud easily.

- Highly visible and reflective at night.
- Usable in all weather conditions.
- Made of most durable Polyurethane.
- Anti-slipping surface pattern design.
- 3 flashing LED light each side.



Speed Hump

Yellow EPDM Rubber Embedded

Now most speed humps are glued Yellow Reflective Tape, normally the reflective tape would be only last 1-2 years maximum service life. But we embedded the Yellow EPDM rubber into speed hump through a special process, the yellow rubber will not fade, fallen, crack under any condition and environment. Furthermore we provide 5 year quality assurance for all (Yellow EPDM Rubber Embedded) speed humps.

Product Dimension

6 Foot Speed Hump

Model No.: PG-DH-SP-26

Middle: 1830 x 300 x 50mm

End Cap: 190 x 300 x 50mm



Molded Yellow Rubber Piece for longer service life!



Using as Cable/Hose Cover, Provide safe passage for pedestrians and vehicles.



Model No.	Middle Size	End Cap Size
PG-DH-SP-6	1830 x 300 x 50mm	190 x 300 x 50mm
PG-DH-SP-75	1830 x 300 x 75mm	190 x 300 x 75mm

Arrow Speed Hump

Yellow EPDM Rubber Embedded

The Arrow Speed Humps are designed for heavy traffic roads in High Class Markets. The wide body yellow rubber section and white arrow reflectors provide maximal visibility to drivers day and night. Furthermore, the wide body speed hump help the car/truck run-over the speed hump line smoothly without severe shock.

Yellow Rubber Pigment is guaranteed by CIBA® within 2 years!



PG-DH-SP-5



PG-DH-SP-8



Model No.	Part	Length	Width	Height	Weight
PG-DH-SP-8	Middle	500mm	550mm	75mm	14kg
	End Cap	200mm	300mm	50mm	8kg
PG-DH-SP-5	Middle	500mm	1000mm	75mm	23kg
	End Cap	190mm	1000mm	75mm	9kg

European Speed Hump

Yellow EPDM Rubber Coated

All of these series Speed Hump are made from durable recycled tire rubber with Yellow EPDM coating. The yellow/black rubber will not fade, crack under any conditions and environment. We provide 2 year quality assurance for all (Yellow EPDM Rubber Coated) Speed humps.



PG-DH-215



PG-DH-SP-10



PG-DH-SP-7

Model No.	Middle Size	End Cap Size
PG-DH-215	500 x 350 x 50mm	250 x 350 x 50mm

Model No.	Middle Size	End Cap Size
PG-DH-SP-10	330 x 500 x 45mm	250 x 500 x 45mm

Model No.	Middle Size	End Cap Size
PG-DH-SP-7	500 x 400 x 50mm	200 x 400 x 50mm

Rubber Speed Cushion

Rubber Speed Cushions are made from recycled rubber tires. Rubber is lighter and easier to work with than asphalt and concrete, significantly minimizing the number of hours that need to be invested to install the solutions. Embedded reflective material increases visibility and safety, day or night.

Anti-skidding Design



Installation Accessories:



Red Ral3003 Color



Black Color

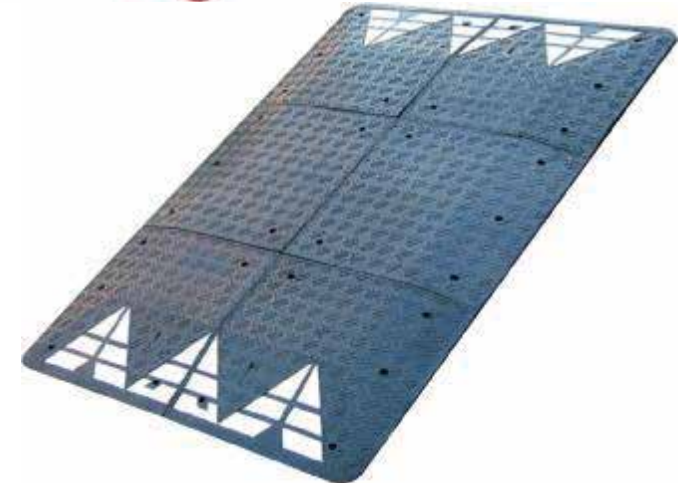

Model No.	Total Length	Total Width	Height	Total Weight	Part	Dimension	Weight
PG-DH-SP-4	3000mm	1800mm	65mm	300kg	Left End	1000 x 900 x 65mm	50kg
					Middle		
					Right End		

Rubber Pedestrian Crossing

- Completely made of vulcanized rubber movable modular parts.
- The upper surface has particular not slippery surface raised stud.
- Fixed to the ground by expansion screws and Bone Connector.
- The particular size of the modular parts maybe used to meet any road.
- High intensity reflective pedestrian crossing sign provide better visibility.



Model No.	Length	Width	Height	Parts	Accessories
PG-DH-PC[6x3]	6m	3m	75mm	20 x Black Middle 20 x White Middle 28 x End Cap 4 x Corner Piece	79 x "1" Connector 72 x Screw Caps
PG-DH-PC[7x4]	7m	4m		42 x Black Middle 42 x White Middle 40 x End Cap 4 x Corner Piece	120 x "1" Connector 128 x Screw Caps



1



2



3

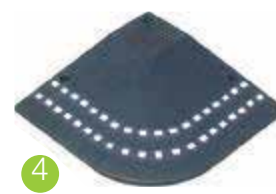

4

The Pedestrian Crossing Speeds up the running vehicles, giving them a vertical acceleration as strong as the vehicle speed; this characteristics wants to push the drivers to limit their speed, avoiding dangerous situations, specially for two wheel vehicles, and avoiding problems to who circulates at normal speed.



Pic	Model No	Part	Length	Width	Height	Reflex
1	PG-PC-B	Black Middle	500mm	500mm	75mm	No
2	PG-PC-W	White Middle				No
3	PG-PC-E	Side Cap				Humanoid
4	PG-PC-R	Corner				Line Marks



Traffic Lane Separator System (Post)

Lane Separators are ideal for merges, gores, eliminating left turns, work zones, and bicycle lane protection.

- Made from recycled rubber.
- Highly visible raised sections keep motorists in lanes.
- Emergency vehicles can cross over separators without losing control.
- Excellent durability and low life cycle costs.



T-Shape Connector



Design for Post



End Cap

30cm - 118cm
Optional Height
Rebondable Post
for Crossing Over
at Emergency!



Model No.	Part	Length	Width	Thickness	Post Height	Weight	Color
PG-DH-TS-M1	Middle	1000mm	275mm	85mm	900mm	15kg	Black/Yellow
PG-DH-TS-E1	End Cap	500mm	275mm	85mm	NO	8kg	Black

Traffic Lane Separator System (Panel)

Lane Separators are ideal for merges, gores, eliminating left turns, work zones, and bicycle lane protection.

- Made from recycled rubber.
- Highly visible raised sections keep motorists in lanes.
- Emergency vehicles can cross over separators without losing control.
- Excellent durability and low life cycle costs.

30cm - 115cm
Optional Height
Rebondable Post
for Crossing Over
at Emergency!



T-Shape Connector



Design for Post



End Cap

Model No.	Part	Length	Width	Thickness	Panel Height	Weight	Color
PG-DH-TS-M2	Middle	1000mm	275mm	85mm	900mm	15kg	Black/Yellow
PG-DH-TS-E2	End Cap	500mm	275mm	85mm	NO	8kg	Black

Extensible Lane Separator System



PIC	Model No.	Rubber Base				Recovery System				Reflex
		Length	Width	Height	Weight	Part	Height	Width	Weight	
1	PG-TS-IMTLP	1000mm	275mm	85mm	14Kg	Post	900mm or more	75mm	1Kg	3x50mm Stripes
2	PG-TS-1MTLFB1					Panel 7	750mm	150mm	0.8Kg	500x130mm HIP Stripes
3	PG-TS-1MTLFB2					Panel 9	910mm	250mm	1Kg	750x250mm HIP Tape

Lane Separator System



PIC	Model No.	Rubber Base				Recovery System				Reflex
		Length	Width	Height	Weight	Part	Height	Width	Weight	
1	PG-TS-7MTLP	900mm	250mm	85mm	13Kg	Post	900mm or more	75mm	1Kg	3x50mm Stripes
2	PG-TS-7TLFB1					Panel 7	750mm	150mm	0.8Kg	500x130mm HIP Stripes
3	PG-TS-7MTLFB2					Panel 9	910mm	250mm	1Kg	750x250mm HIP Tape

Spring Back Delineator Panel

Made up of rubber base, TPU Spring Back Foot and ABS Delineator Panel.

- Double side high intensity prismatic tape.
- Handle hole design for easy move for temporary application.
- The ABS Delineator Panel could be assembled without specific hardware.



PIC	Model No.	Rubber Base				Recovery System				Reflex
		Length	Width	Height	Weight	Part	Height	Width	Weight	
1	PG-TS-5CB1	350mm	320mm	100mm	5kg	Panel	750mm	150mm	0.8kg	500x130mm HIP Stripes
2	PG-TS-5CB2	600mm	320mm	100mm	12kg	Panel	910mm	250mm	1.0kg	750x250mm HIP Stripes

Collapsible Delineator Panel

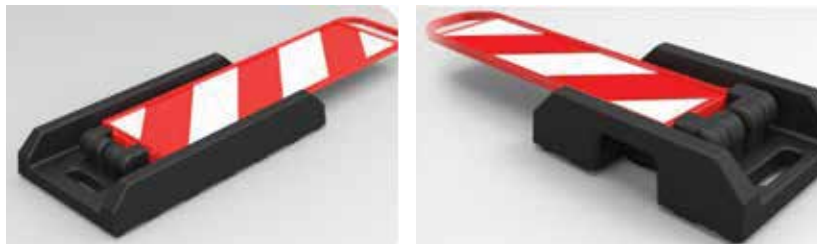

PIC	Model No.	Rubber Base				Recovery System				Reflex
		Length	Width	Height	Weight	Part	Height	Width	Weight	
1	PG-TS-5LFB1	350mm	320mm	100mm	5kg	Panel	750mm	150mm	0.8kg	500x130mm HIP Stripes
2	PG-TS-4LFB2	600mm	320mm	100mm	12kg	Panel	910mm	250mm	1.0kg	750x250mm HIP Stripes





PG-DH-300



PG-DH-302



PU Lane Divider

A flexible flag with vivid color installed on a base is very easy noticed by driver while driving; Flag with reflective sheet work normally in night and bad weather, such as rain or snow; The flag is made from flexible rubber with the best flexible character and vivid color;

Model No.	Height	Base Size	Materials	Weight	Color
PG-DH-300	300mm	220x150mm	Polyurethane	1.5kg	Yellow
PG-DH-302	300mm	220x150mm	Polyurethane	1.5kg	Yellow

Stackable T-Top Delineator Cone

- Flexible polyethylene post with reflective striping
- Sturdy 8 kg recycled rubber base.
- Two-piece design for ease in storage & handling.

Product Dimension
Model No.: PG-DH-GC-2
 Height: 150mm
 Base Width: 420mm
 Weight: 8.0kg
 Reflex: 2x10cm/25cm
 High Intensity Reflective Tape

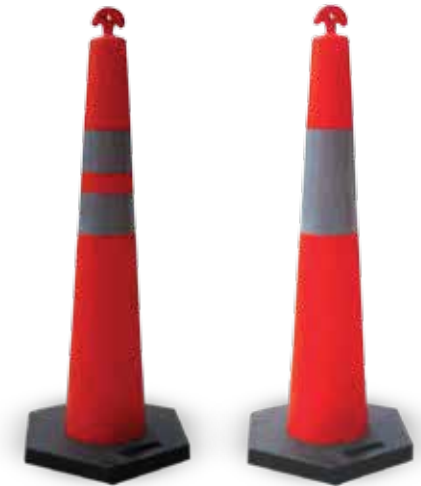

1. T-Top Delineator Post
2. T-Top Delineator Post
3. Loop-Top Delineator Post

Molded Lower Handhold Grip

- Standard with molded lower handhold grip.
- Convenient T-top carry handle and molded in bolt hole for flashing light.
- Improved recesses create a deeper area of reflective bands.
- Stronger ribs provide maximum band protection.

Model No.	Post Dia	Height	Base Width	Reflex Height	Base Weight	Total Weight
PG-DH-GC-1	100mm	1150mm	420mm	25cm 2x10cm	6kg/8kg	7kg/8kg
PG-DH-GC-3	100mm	1150mm	420mm	25cm 2x10cm	6kg/8kg	7kg/8kg
PG-DH-GC-1	100mm	1150mm	420mm	2x10cm	6kg/8kg	7kg/8kg

T-Top Retractable Topper



Product Dimension
Model No.: PG-DH-Top-3
 Band Length: 9.0 m
 Band Color: Yellow/Black
 Red/White
 Shell Height: 250mm
 Shell Color: Orange/Yellow
 Band Brake System: Included

This retractable T-Top Topper is designed to connect with T-Top Delineator Post, it could be extend out to 9m with a 50mm width striped safety band. It features four sided sonnections for cordoning off a restricted area or building a temporary barrier.

T-Top Accessories



T-Top Chain Lock



Barricade Light

Ultra Durable Assemble TPU Flexible Post

The Flexible City bollard looks like metal, but actually it was made of polyurethane. The bollard will gently bend when impacted by a vehicle bumper. These bollard will not break or crack when Car/Truck driven over and they rebound quickly after being impact/press.



Stock Color



Black

Custom Color



Orange



Green



Blue



Yellow



White

1

Flexible City Bollard with Square Base



2

Flexible City Bollard with Square Base



PIC	Model No.	Height	Base Width	Weight	Reflex tape	Bearing Capacity
1	PG-DH-FCB-45	450mm	200mm	1.1kg	2 x 50mm HI Tape	20 tons weight at 60km/h speed
	PG-DH-FCB-75	750mm		1.4kg	3 x 50mm HI Tape	
	PG-DH-FCB-100	1000mm		1.7kg	4 x 50mm HI Tape	
2	PG-DH-FCB-45S	450mm	140mm	1.1kg	2 x 50mm HI Tape	20 tons weight at 60km/h speed
	PG-DH-FCB-75S	750mm		1.4kg	3 x 50mm HI Tape	
	PG-DH-FCB-100S	1000mm		1.7kg	4 x 50mm HI Tape	

Economical Flexible Post

These items are made of Durable TPU Recovery Base System and Economical LDPE Bollard, the special “)(” would be high impact resistant, the upper post could be removed or replaced easily without dismounting the base. The Bollard Diameter are available at 50mm or 70mm. The Bollard Height are available from 900mm - 1500mm for you.



Special “)(” Flexible Structure



Locking bollard onto base by rivet

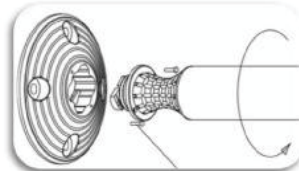

Rotational and Screw Double Locking System



Testing by Car Impacting

Any other height, color of reflex stripes are able to be custom-made.

- Round Bollard provides 360° of reflectivity.
- Made of durable polypropylene for flexibility and strength.



Model No.	Standard Height	Bollard Diameter	Base Width	Reflex Tape	Bearing Capacity
PG-DH-RP-90	900mm	70mm/50mm	200mm	3 x 50mm HI Tape	5 tons weight at 100km/h speed
PG-DH-AFP-105	1050mm			4 x 50mm HI Tape	
PG-AFP-120	1200mm			4 x 50mm HI Tape	

TPU Single-Place Flexible Post

- Made of Durable TPU Materials with fluorescence orange.
- Thread design in the bottom increase the resilience.
- Recessed design of reflective tape area.
- Applicable to hot and cold environment.



Available in Multiple Color



Testing by Fork Truck



PIC	Model No.	Height	Base Width	Weight	Reflex tape	Bearing Capacity
1	PG-DH-FP-45	450mm	200mm	0.9kg	2 x 50mm HI Tape	20 tons weight at 60km/h speed
2	PG-DH-FP-75	750mm		1.2kg	3 x 50mm HI Tape	

Plastic Fence Barrier

Blowing Type

- Perfect barrier for sporting events, festivals and parades.
- With red, white or yellow color engineer grade reflective tape.
- Lightweight and easy-to-handle.
- Great for indoor or outdoor use.
- Includes connecting device to join units together.
- Durable polyethylene construction with red, white or yellow reflective sheeting.
- Legs clip into barrier for stacking, transportation and storage, can be adjustable in 360°.



PG-DH-PFB-1



Model No.	Length	Base Width	Height	Body Height	Weight	Color
PG-DH-PFB-1	2000mm	400mm	1000mm	800mm	12kg	Orange/Yellow

Plastic Expandable Barrier

Blowing Type

Light weight and easy to carry, you can adjust the length according to the actual work request , the maximum length is 2.5 m. Side stent design to increase water injection weight, improve the stable performance when the product in the protection. Adjustable stem position among paste high brightness reflective material, greatly improving the safety warning role of products in the process of using . Products are especially suitable for temporary construction, equipment maintenance, emergency the scene of the accident isolation and other places.

- Made form durable plastic by blowing.
- Expandable from 220mm to 2500mm.
- Able to filled water for increasing water.
- Durable rubber legs to enhance reliability.

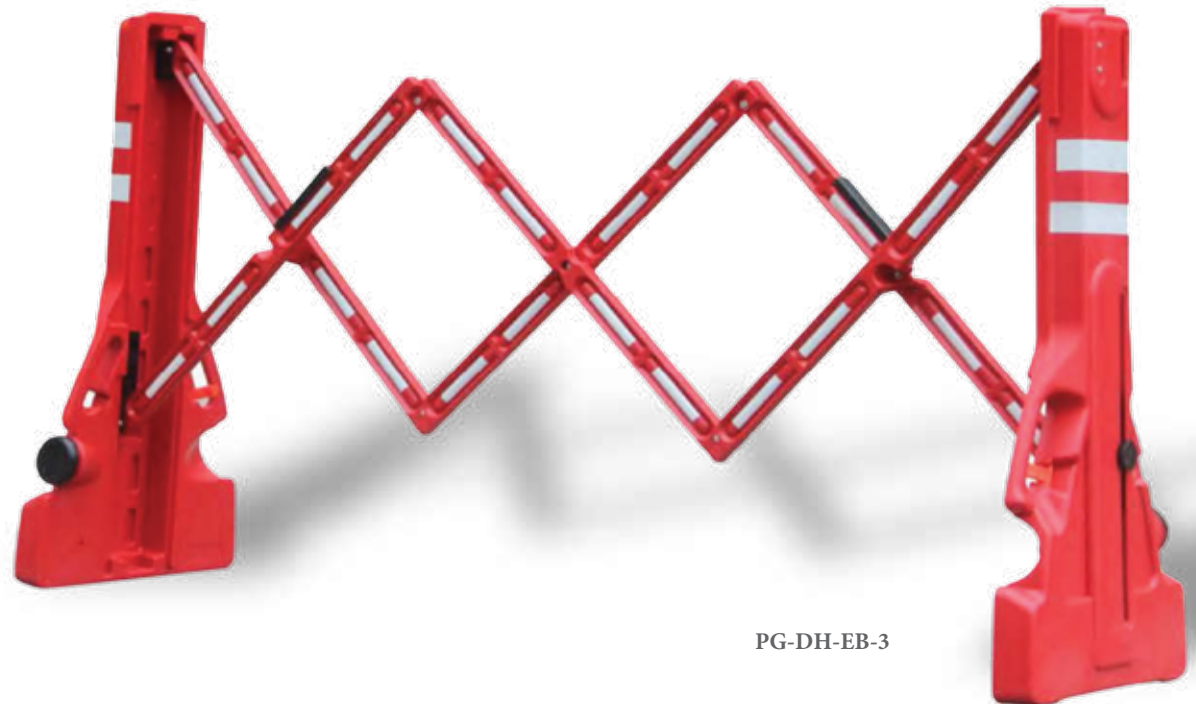

PG-DH-EB-3

Model No.	Shorten Length	Extension Length	Width	Height	Weight	Color
PG-DH-EB-3	220mm	3500mm	420mm	950mm	6.0kg	Red

Plastic Expandable Barrier

Made of durable plastic, this easy to handle barrier is an ideal safety or traffic control unit. It is durable, maintenance free, temperature resistant, and will not damage or scratch floors. This barricade can link together with other units for additional security. Some minor assembly is required.

- Made from durable plastic injection.
- Expandable from 420mm to 3500mm.
- Detachable rubber legs to enhance reliability.



PG-DH-EB-1

Model No.

PG-DH-EB-1

Shorten Length

450mm

Extension Length

3500mm

Width

420mm

Height

950mm

Weight

6.0kg

Color

Yellow

Australia Board Barrier

The Australia barrier board system is ideal for construction sites and outdoor applications where a tough and durable barrier system is required. The yellow, ABS plastic board is supported by powdercoated steel legs. Length: 2.5metres. The yellow boards with class 1 reflective stripes meet highway use requirements.



Two Type Trestle for Options

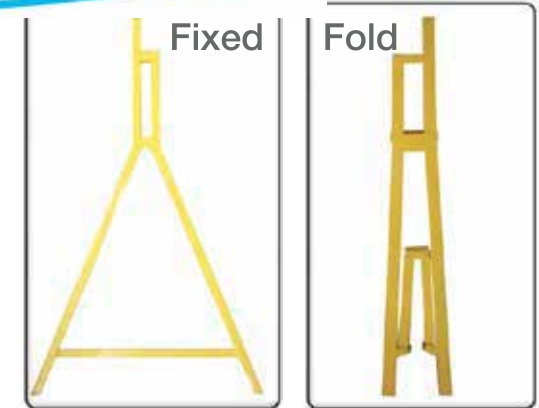

Model No.	Part	Length	Width	Height	Weight
PG-DH-BB-1	Fixed Trestle	1000mm	715mm	50mm	3.0kg Each
	Foldable Trestle	1000mm	200mm	50mm	3.5kg Each
	Reflective Trestle	2500mm	190mm	30mm	2.5kg

Water Filled Barrier

Whether the requirement is to redirect, separate or delineate traffic, protect pedestrians from moving vehicles or provide a high visibility presence, our range of water filled safety barriers will provide you with many years of service and protection.

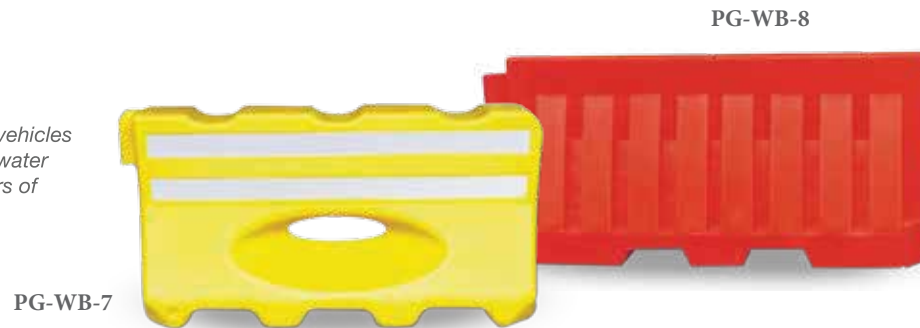

Model No.	Length	Height	Top Width	Bottom Width	Weight	Water Capacity
PG-WB-1	600mm	600mm	150mm	400mm	4kg	60kg
PG-WB-5	1500mm	800mm	250mm	460mm	16.5kg	250kg
PG-WB-8	1300mm	650mm	200mm	400mm	9.5kg	200kg
PG-WB-7	2000mm	800mm	145mm	400mm	19kg	400kg
PG-WB-4	1650mm	650mm	150mm	450mm	12.5kg	300kg



Barrier Fence Mesh

Safety fence is also named as warning barrier and snow fence. The main color is orange, designed for warning. It adopts PE as major raw material with UV added in manufactured through plasticizing. It is featured with high strength, ageing resistance, anti-corrosion, softness and portability, and recycle. The main mesh is rectangular and oval. The width is in the range from 1m to 1.80m. Many different mesh sizes and specifications are available for these products and multiple diverse products can be customized as per customers' requirements.



It adopts PE as major raw material with UV added in manufactured through plasticizing. The main color is orange, designed for warning.

Mocel No.	Height	Length	Mesh Size W	Weight/Sq. M	Total Weight
PG-BR-114	1.0 Meter	50 Meter	100x40mm	120g	6kg
PG-BR-124	1.2 Meter	50 Meter	100x40mm	120g	7.2kg
PG-BR-154	1.5 Meter	50 Meter	100x40mm	120g	9kg
PG-BR-184	1.8 Meter	50 Meter	100x40mm	120g	10.8kg

Traffic Flag

Reinforced warning flag promotes safety with high visibility.



- **Flag Size**
46cm (18in); 61cm (24in)
- **Hold Wood Staff**
61cm (24in); 76cm (30in)

Traffic Flag

White nylon rope cord with 45pcs, 28 x 16cm orange vinyl flags, UV stabilised rope 30m per roll.

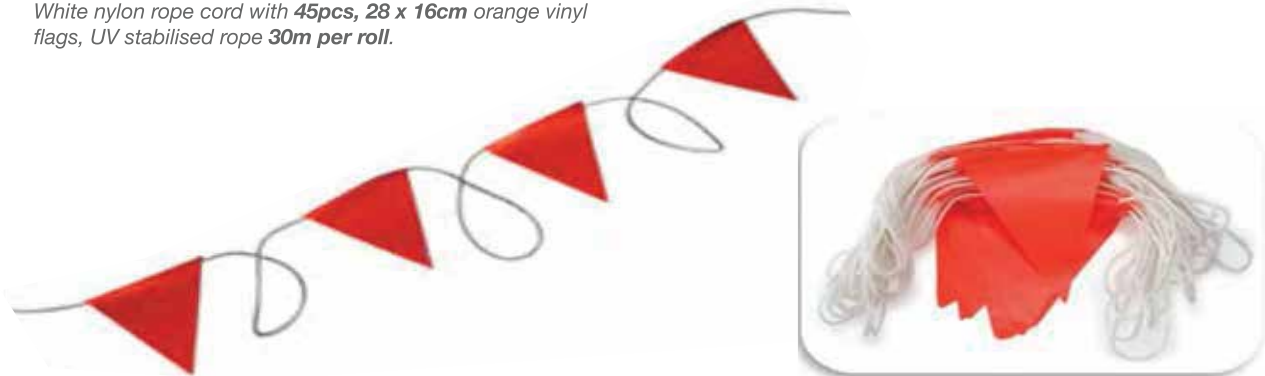

Parking Lock

Parking Lock and Position Lock was used to protect your parking space by standing guard while you and your vehicle are away. You can feel at ease that no vehicle can park in your space and give inconvenience for you.



O Type



A Type

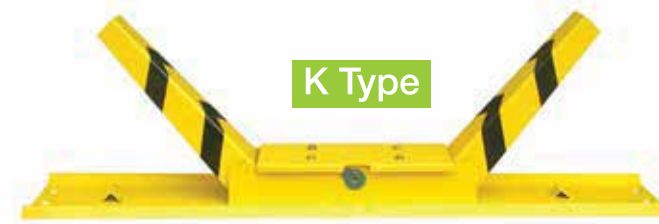

K Type



T Type



I Type



M Type

Model No.	Type	Length	Width	Original Height	Risen Height	Weight
PG-PB-O	O	500mm	600mm	80mm	380mm	7.5kg
PG-PB-A	A	650mm	200mm	80mm	400mm	7.0kg
PG-PB-K	K	1000mm	85mm	80mm	190mm	7.5kg
PG-PB-T	T	495mm	495mm	90mm	495mm	7.0kg
PG-PB-I	I	74mm	90mm	90mm	690mm	6.0kg
PG-PB-M	M	680mm	290mm	50mm	410mm	2.5kg

Plastic Road Stud



PG-DH-RS-1

PG-DH-RS-2

Model No.	Length	Width	Height	Reflector	Weight	Color
PG-DH-RS-1	100mm	100mm	20mm	PC Prism	0.15kg	White/Yellow
PG-DH-RS-2	100mm	100mm	20mm	43 Bead Glass	0.15kg	White/Yellow

Aluminum Road Stud



PG-DH-RS-2

PG-DH-RS-3

PG-DH-RS-6

Model No.	Length	Width	Height	Reflector	Weight	Color
PG-DH-RS-2	100mm	100mm	70mm	PC Prism	0.30kg	White/Yellow
PG-DH-RS-3	100mm	100mm	70mm	43 Bead Glass	0.30kg	White/Yellow
PG-DH-RS-6	100mm	100mm	70mm	43 Bead Glass	0.35kg	White/Yellow



Model No.	Length	Width	Height	Reflector	Weight	Color
PG-DH-RS-5	108mm	101mm	22mm	6 Flash LED	0.30kg	White/Yellow
PG-DH-RS-9	132mm	122mm	70mm	6 Flash LED	0.80kg	White/Yellow
PG-DH-RS-6	115mm	184mm	70mm	4 Flash LED	0.50kg	White/Yellow

Solar Road Stud

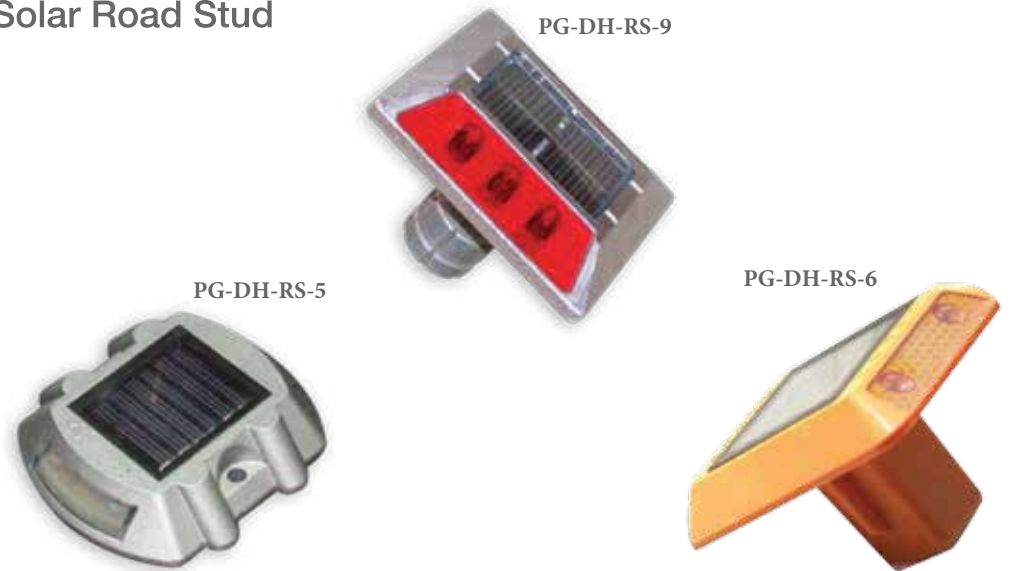

PG-DH-RS-9

PG-DH-RS-5

PG-DH-RS-6

Non-Reflective Pavement Marker

Non-reflective pavement markers that provide tactile feedback to drivers when they move across designated travel lanes. Made of durable ABS plastic. Formed protrusions on base provide greater bonding on surface.



PG-DH-RS-10



Non-Reflective Pavement Marker

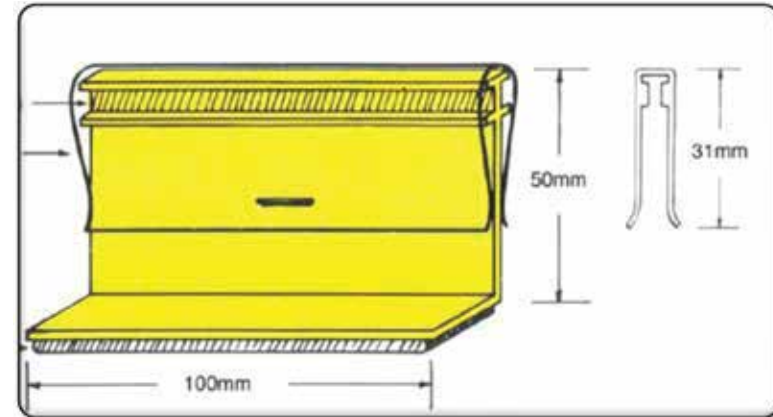

The Temporary Road Markers are the most economical choice for temporary lane markings. These markings can be installed quickly and easily by a worker with no equipment, providing huge savings in time, money and worker exposure vs. paint or temporary pavement marking tape.

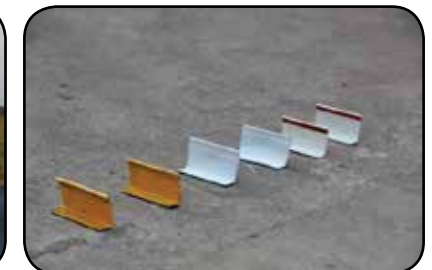

Model No.	Diameter	Height	Material	Color
PG-DH-RS-10	100mm	20mm	ABS	Yellow/White or any other color

Plastic Convex Mirror

- 90° angle lens offers visibility increase.
- Durable bottom casing to protect battery casing.
- One piece battery compartment works with gravity for better conductivity.



PG-BL-1



PG-BL-2



PG-BL-3



PG-BL-4

Model No.	Height	Length	Width	Light Source	Drive Mode	Color
PG-BL-1	330mm	180mm	75mm	6 LED	Dry Battery	Yellow/Red
PG-BL-2	330mm	180mm	75mm	6 LED	Solar	Yellow/Red
PG-BL-3	360mm	190mm	110mm	6 LED	Dry Battery	Yellow/Red
PG-BL-4	330mm	180mm	75mm	6 LED	Dry Battery	Yellow/Red

LED Traffic Baton

- Rugged Design.
- Shock & weather resistant.
- Rubber "O" ring battery compartment seal.
- 1 mile visibility at night-lowlight conditions.
- 53cm total length/ 3cm diameter lens.
- 240g only with batteries installed.
- Red flash solid on & glow mode.
- Drived by 1pc D battery.



Permanent Marking Tape

Permanent Marking tapes are embedded micro glass beads both on surface, has a durable, reflective & skidproof effect. Designed to stripe asphalt parking lots, roads, bike paths and any other area where the road will subject to heavy traffic flow and high visibility delineation is needed.

Available in 6 colors:



Fix onto Ground Easily

Glass Bead Embed

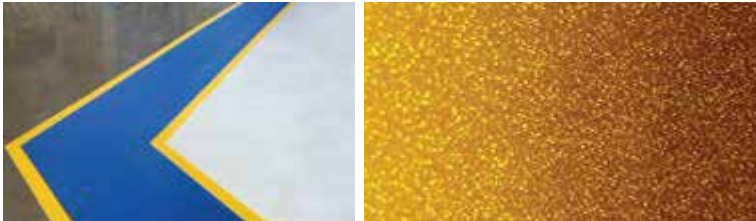

Caution Stripe Tape



Available in Yellow/Black & Orange/White. Also available in 50mm, 75mm, 100mm width. 50meter/Roll. Any color can be custom-made.

Hazard Warning Tape



Caution Tape

Caution tape are a quick & effective way to create a visual fortress around temporary hazards. This lightweight tape can be tied, stapled or nailed to posts, fences or barricades. Ideal for outdoor and indoor application such as crowd and traffic control. BRC...

- Standard Width- 50mm/75mm
- Standard Length- 100meter/Roll



Plastic Chains



Model No.	Length	Width	Reflector	Weight	Color
PG-PC-4	4mm	25x18mm	50meter/roll	2.0kg	Red/White
PG-PC-6	6mm	41x21mm	50meter/roll	3.1kg	Red/White
PG-PC-8	8mm	50x26mm	50meter/roll	5.5kg	Red/White
PG-PC-10	10mm	54x39mm	25meter/roll	5.2kg	Red/White

Plastic Convex Mirror

Made from PC Mirror and ABS Back

- Suitable for convenient shop, big supermarket, parking lot and any other corner where need an anti-thief.
- Not easy to consume, anti-ultraviolet radiation, can use for a long time.
- Firm, long time using and anti-crash.
- Clear and definite mirror image, easy and convenient installation.
- Weight of mirror is light, it can be safely use.



Indoor Type

Model No.	Diameter
PG-CM-20	200mm
PG-CM-30	300mm
PG-CM-45	450mm
PG-CM-60-1	600mm
PG-CM-80-1	800mm



Outdoor Type

Model No.	Height
PG-CM-60-2	600mm
PG-CM-80-2	800mm
PG-CM-100	1000mm
PG-CM-120	1200mm

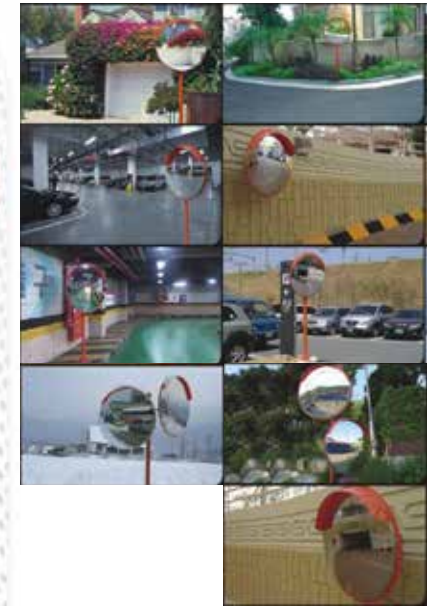

Stainless Safety Mirror

Made from Stainless Steel Mirror and Back

- Best-quality, premium products.
- Stainless material has no change of visibility (spots & cloudiness of mirror's surface).
- 3600mm curvature radius meets the standards of the Ministry of Construction and Transportation.

Model No.	Mirror Diameter	Curvature Radius	Distance of Visibility
PG-SCM-60	600mm	2200mm	≤ 40M
PG-SCM-80	800mm	3000mm	40-60M
PG-SCM-100	1000mm	3600mm	≥ 60M



Vehicle Mounted

Item No.: PG-DN-VMV1C-B1

Variable Message Sign

Options:

- Advance Hand Hold Controller
- Mobile Phone Software

Specification:

- Dimension : 1350 x 850 x 70mm
- Viewing Window : Polycarbonate
- 2 actuators for raise and lower
- LED Pixel : 80 X 48 pixels
- LED Angle : 30° viewing angle
- LED Life : 100000 hours
- Visual Distance : more than 300m
- Power : 12V DC
- Operating Temp : -20° C to +70° C
- Weight : 45kgs
- Guarantee : 1 year

Trailer Mount

Traffic Arrow Board

Arrow Board Specification:

- Dimension : 1500 x 750 x 50mm
- Paint : All powder coated
- Flash black finish to reduce glare
- LED Angle : 30° viewing angle
- LED Life : 100000 hours
- Visual Distance : more than 300m
- Power : 12V DC or solar power
- Operating Temp : -20° C to +70° C
- Guarantee : 1 year

Arrow Board Specification:

- Length with Tongue : 2750mm
- Width with Fenders : 1380mm
- Max Working Height : 2850mm
- Wheels & Tires : 13" 165R/70R13
- Weight : 225kgs
- Battery/Controller Box: Steel fabrication, lockable



Triple Color Mobile VMS + Big Trailer



VMS Specifications

Pitch	P32 mm
Resolution	64 H x 96 W pixels
VMS Display Size (mm)	2048 mm x 3072 mm
Pixel Composition	2R1G
Display Color	Red, Green, Amber
Brightness	≥ 7500 nits
Viewing Angle	90°/40°
VMS Communication	RS232/RS485, Ethernet, GPRS
Lifting Device	Hydraulic System
Weight[VMS+Trailer]	1230kg
Trailer Tire [inch]	14"
Battery	4 pcs of 185AH/12V
Solar Panel	4 pcs of 100W/12V
Remote Control	Yes
AC Charger for Battery	600W/12V
RF Medium	No

WMG-Small VMS and Small Trailer



Specification:

- Pitch : 40mm
- Resolution : 24 H x 48 W pixels
- Display Area : 960mm H x 1920mm W
- Pixel Composition : 4 A
- Display Color : Amber Color
- Brightness : > 7500 nit
- Communication : RS232, 2G/3G Modem, USB
- Voltage : DC 12V/24V
- GPS Function
- Radar Detect Vehicle Speed Function
- Solar Panel : 150W
- Battery : 150 AH

WMG-Amder Color Mobile VMS and Big Trailer

Specification:

- Pitch : 55mm H x 50mm W
- Resolution : 28 H x 48 W pixels
- Display Area : 1540mm H x 2400mm W
- Pixel Composition : 4 A
- Display Color : Amber Color
- Brightness : > 7500 nit

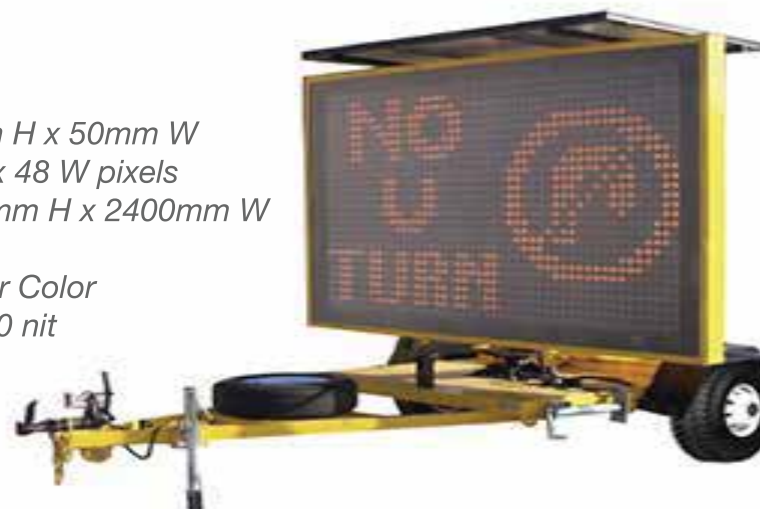

Mobile Traffic Light
Model PG-TSU-3-205



200AH Battery
45Wx2 Solar Panel
200 traffic
signal head



Handheld Remote Control



AC Charger Available



Bolt: connect and drag 2 trailers at a time



20 channels controller



Retractable drag head

- The trailer mobile traffic signal is built with four groups of 200mm/300mm traffic signals facing four directions respectively and each group is comprised of 3-5 signal aspects.
- The LCD monitor on the control panel with intersection simulating functions makes site operations easy and fast. The users can use a remote controller to set the phase automatically and manually, or to lift up and lower down the LED traffic signal mast.
- The electrical hydraulic lift system can adjust the signal height between 2200,-3500mm. Even at the maximum height of 3.5m, the whole system remains firm and steady.
- Auto brightness control is available too.
- It is equipped with a 20 channel/5A independent output controller.
- The trailer mobile traffic signal is designed and built as a trailer. It can be pulled by a truck and a truck can haul 2 sets at a time.
- Both dragging arm and auxiliary support wheels are retractable. Four retractable supporting kiskstands can be fixed on the ground by screws to make sure the system can stand on the ground firmly.

Specifications	
Dimension LxWxH [mm]	1640x1162x2414mm
Maximum Height [mm]	3500mm
Weight [kg]	450kg
Tire [inch]	13"
Lighting Device	Hydraulic Cylinder
Battery	2pcs of 100AH/12V
Solar Panel	2pcs of 45W/12V
Remote Control	Yes
AC Charger for Battery	600W/12V
RF Modem	No



Mobile Traffic Light
Model PG-TSU-5-303



Traffic Controller



Mobile Traffic Light
Model PG-TSU-1-303



Release the east-bound traffic flow (shuttle mode) Release the west-bound traffic flow (shuttle mode)

Specifications	
Dimension LxWxH [mm]	721x671x2270mm
Maximum Height [mm]	2620mm
Weight [kg]	80kg
Tire [inch]	10"
Ligting Device	Manual Control
Battery	1pc of 100AH/12V
Solar Panel	1pc of 45W/12V
Remote Control	Yes
AC Charger for Battery	600W/12V
RF Modem	Yes

Specifications	
Dimension LxWxH [mm]	850x850x3000mm
Maximum Height [mm]	3000mm
Weight [kg]	220kg
Tire [inch]	5"
Ligting Device	No
Battery	2pcs of 100AH/12V
Solar Panel	2pcs of 45W/12V
Remote Control	Yes
AC Charger for Battery	600W/12V
RF Modem	No

LED Arrow Board

WMG arrow boards have been designed and built to various international standards. Being very simple and compact in structure, easy and convenient in operation, WMG arrow boards are widely used in China, U.S.A, England, Australia, New Zealand, Qatar, Singapore, Brazil, Iran, Ireland, and Hong Kong, etc.

- Ultra bright TS LEDs with uniform and penetrating brightness
- Up to 1,200 meters of viewing distance
- Unique seamless aluminum cabinet design for the boards to stand all tough conditions,

Only found on WMG arrow boards:

- Constant current drive; High reliability, stability, slow degradation and low power consumption
- Easy to operate with small and compact control box for multiple indicating patterns
- Multiple power protection mechanism, lamp status detection and indication
- Automatic/Manual brightness adjustment, attractive and comfortable lighting source
- Long work life of up to 50,000 hours
- DC 12V/24V available; solar panel optional
- Aluminum cabinet with polycarbonate lamp shell, flexible, shock-proof, rigid and all-weather use
- Can be mounted onto all kinds of constructing vehicles, trucks or trailers

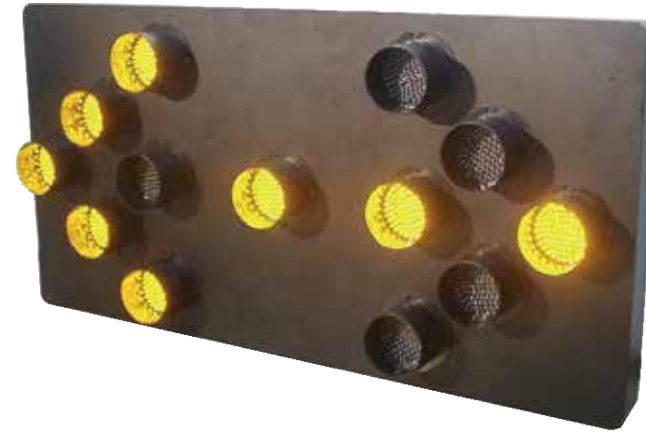

Super bright LED Panel



Remote Control



Dimension

Model No.	Dimension		Weight
	Length	Height	
PG-DXP-01	1140mm	350mm	16
PG-DXP-02	1440mm	500mm	26
PG-DXP-03	2360mm	820mm	51
PG-DXP-04	1748mm	654mm	38

Specifications

Optical and Electrical Specs

- Luminous Intensity: $\geq 150\text{cd/head}$ (100% Brightness)
- Working Voltage: 12V(10.5~15V) or 24 V (22~28 V)
- LEDs used and power consumption

Model No.	LEDs/head	Diameter of each LED head	Power Consumption	Remarks
PG-DXP-XXATXX	32pcs	100mm	23W	12V/24V
PG-DXP-XXBTXX	32pcs	100mm	25W	12V/24V
PG-DXP-XXCTXX	32pcs	100mm	27W	12V/24V
PG-DXP-XXDTXX	32pcs	100mm	27W	12V/24V

Possible Patterns for Arrow Boards

TYPE A & INDICATION PATTERNS

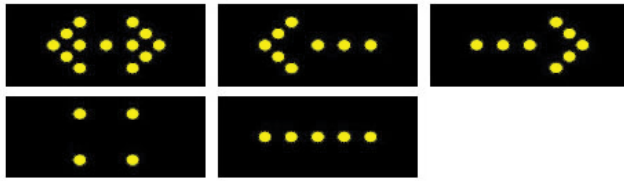

TYPE B & INDICATION PATTERNS

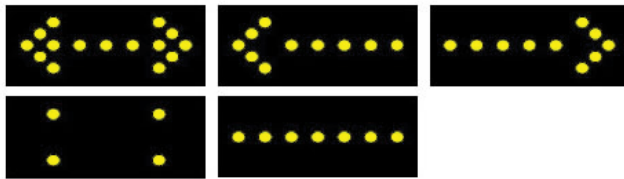

TYPE C & INDICATION PATTERNS

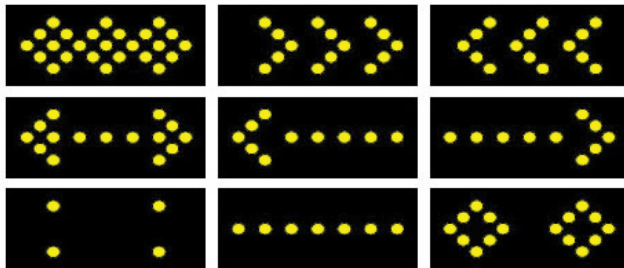

TYPE D & INDICATION PATTERNS



Connection and Control of Arrow Boards

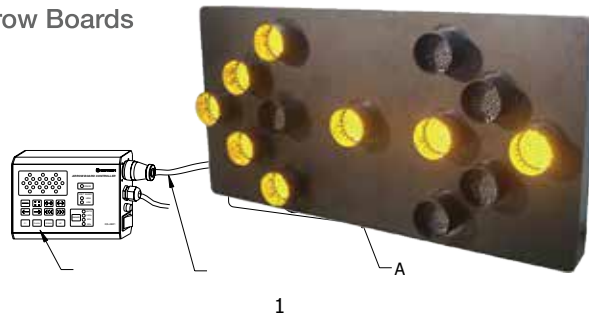

1

Arrow Board + Small Trailer

- LED Cluster : 100mm
- Cluster Quantity : 23pcs
- Solar Panel : 45w
- Battery : 100AH/12V
- AC Charger for Battery (available)
- Remote Control





PRIVATE GLOBAL TRADING AGENCIES

PRIVATE GLOBAL TRADING AGENCIES LLC

📍 Located in UAE-ABU DHABI as one of the leading partners and manufacturers of all kinds of safety products.

📞 + 971 26658832

✉️ INFO@PRIVATEGTA.COM

www.Privategta.com